

KNIPEX Quality – Made in Germany

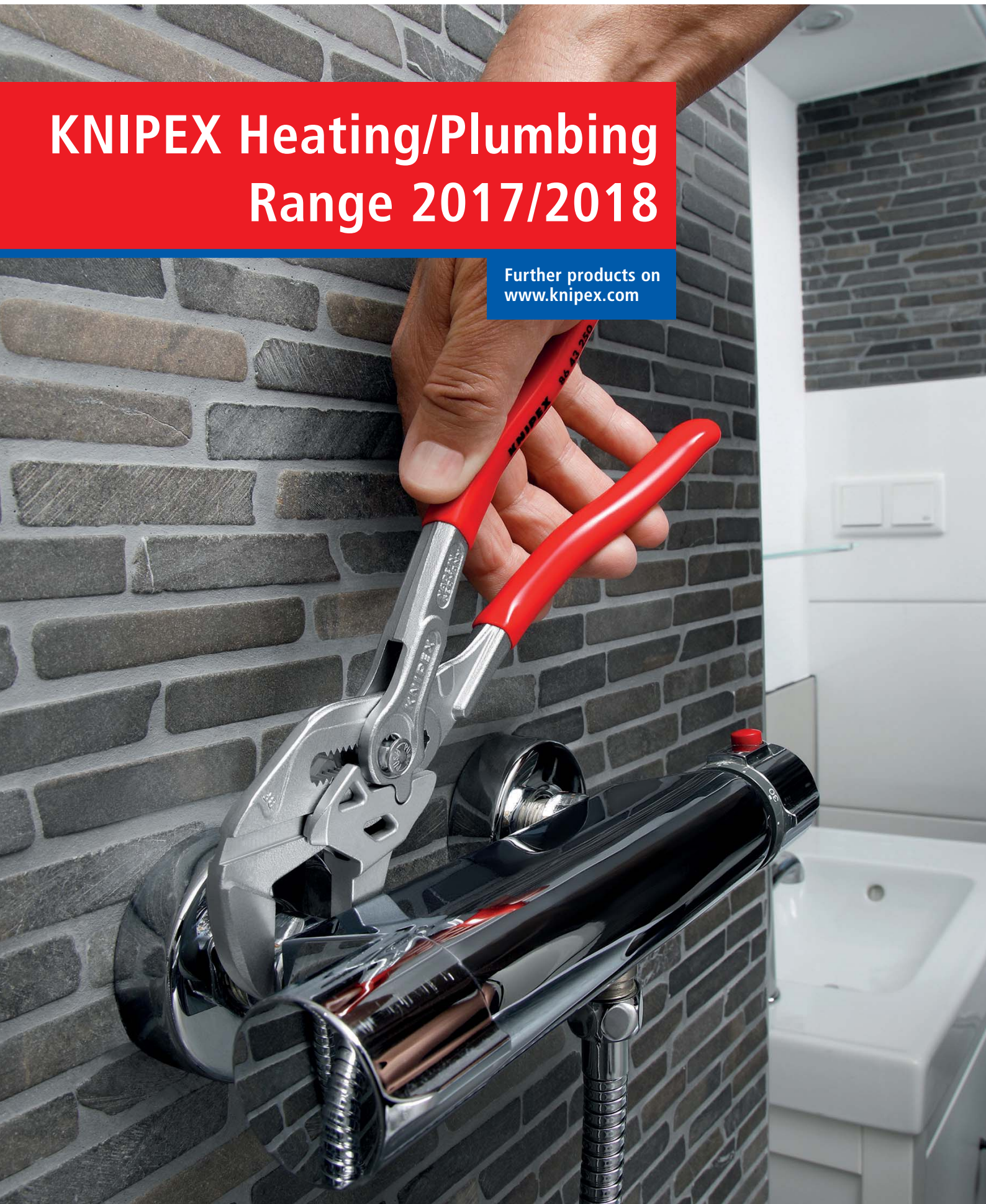

KNIPEX Heating/Plumbing Range 2017/2018

Further products on
www.knipex.com



Pliers for the heating/ plumbing trade

All plumbing, heating and air conditioning professionals use a wide range of tools in their everyday work. The one they reach for most frequently are pliers, because they can be used universally for diverse jobs. KNIPEX pliers have been improved by numerous advances, thereby enabling the professional to work quickly, easily and safely. The best example is our classic, the KNIPEX Cobra®. The latest innovation is the Cobra® QuickSet. According to the motto "Fully open, push, grab!", it substantially speeds up the screwing process. The locking part engages securely as soon as the tool is under load, so that you can start unscrewing.





































The KNIPEX pliers wrench has been designed for work on quality screw connections made of brass, gunmetal or stainless steel or on chrome-plated fittings. It combines pliers and an open end wrench in one tool. There are six different sizes of pliers wrenches in the basic version for gripping wrench openings of up to 85 mm or 3 3/8".

The KNIPEX X-Cut® diagonal cutters have shown themselves to be an all-rounder that can be used to effortlessly cut anything from fine copper strand through to hard piano wire. When installing panel heating, the innovative pipe cutter for composite and protective pipes is the ideal tool.

Discover these and other pliers from our range for the heating/plumbing trade.



SYMBOLS

	flat jaws		with lead catcher		electrostatic discharging, dissipative		weight
	half-round jaws		angle		electronics		length
	round jaws		centre cutter		VDE tested, also in compliance with GPSG		soft wire
	flat and pointed jaws		cutting edges with bevel		insulated according to IEC 60900. usable up to 1000 V AC/1500 V DC		medium hard wire
	box joint		cutting edges with small bevel		insulated according to DIN VDE 0680/1. usable up to 1000 V AC / 1500 V DC		hard wire
	bolted joint		cutting edges with very small bevel		conforms to a European directive		piano wire
	smooth gripping surfaces		cutting edges without bevel		mechanically tested in accordance with the equipment and product safety act		Cu- + Al-multi-conductor cable, solid and multi-stranded
	knurled gripping surfaces		for flush cut of soft materials				wire rope
	cross-hatched, knurled gripping surfaces		New Article		WEEE marking (Waste Electrical and Electronic Equipment Directive)		iron
	with opening spring						ribbon cable
							steel wire armoured cable (SWA)

Pliers Wrenches

pliers and a wrench in a single tool

Replaces the need for sets of metric and imperial spanners
Smooth jaws for damage free installation of plated fittings - working directly on chrome!

- > Also excellent for gripping, holding, pressing and bending workpieces
- > Zero backlash jaw pressure prevents damage to edges of sensitive components
- > Push the button for adjustment on the workpiece
- > Parallel jaws give a more solid grip; its design allows flexible adjustment of all widths up to the specified maximum size
- > Reliable catching of the hinge bolt: no unintentional shifting
- > The ratchet type principle allows quick and easy tightening and release of all bolted connections
- > Lever transmission greater than 10 : 1 for strong gripping power
- > Chrome vanadium electric steel, forged, oil-hardened

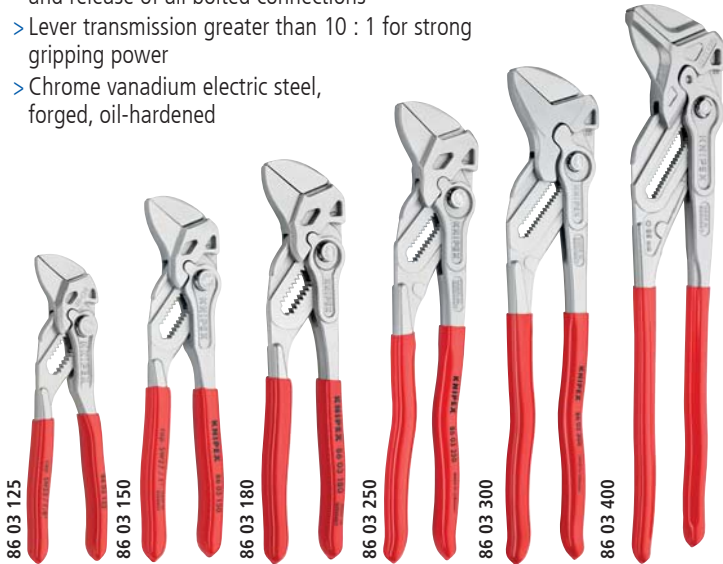

Article No.	EAN 4003773-	Adjustment positions	Inch	mm	mm
86 03 125	077497	11	7/8	23	125
86 03 150	069676	14	1	27	150
86 03 180	035466	13	1 3/8	35	180
86 03 250	033837	17	1 3/4	46	250
86 03 300	041429	22	2 3/8	60	300
86 03 400	077312	25	3 3/8	85	400
86 43 250 N	081296	17	1 3/4	46	250



The mini pliers wrench: Particularly suitable for working on small bolted connections. Excellent access in very confined areas.



86 03 400: For opening widths up to 85 mm / 3 3/8"

NEW

86 03 400



86 03 125



86 43 250



86 43 250: 15° angled pliers handle provides space for counter screw connections or bolted fittings on surfaces; Reduced risk of knuckle injuries

Tile Breaking Pliers

For the precise cutting (breaking) of tiles and porcelain stoneware after scoring with a tile cutter
Ideal for long and thick tiles

- > Ideal protection of tiles against damage: replaceable positioning jaw made from soft, stable plastic
- > Great crushing force thanks to 10-fold increase of manual force
- > Easily adjusted to the required tile thickness at the press of a button
- > Chrome vanadium electric steel, forged, oil-hardened



Plastic positioning jaw: tilting for a clean break line and optimum protection of the tiles against damage



Article No.	EAN 4003773-		mm
91 13 250	079538		250
91 19 250 01	079545	Spare jaw for 91 13 250	



- > Push the button for adjustment on the workpiece
- > Fine adjustment for optimum adaptation to different sizes of workpieces and a comfortable handle width
- > Self-locking on pipes and nuts: no slipping on the workpiece and low handforce required
- > Gripping surfaces with special hardened teeth, teeth hardness approx. 61 HRC: high wear resistance and stable gripping
- > Box-joint design for high stability due to double guide
- > Reliable catching of the hinge bolt: no unintentional shifting
- > Guard prevents operators' fingers being pinched
- > Chrome vanadium electric steel, forged, multi stage oil-hardened



Cobra® XL (87 01 400):
Greater gripping capacity but much lower weight than comparable pipe wrenches. Large gripping capacity of 95 mm, which requires a 3-inch pipe wrench.



Article No.	EAN 4003773-	Adjustment positions	Ø Inch	Ø mm	mm	mm
87 01 125	069935	13	1	27	27	125
87 01 150	060116	11	1 1/4	32	30	150
87 01 180	022015	18	1 1/2	42	36	180
87 01 250	022022	25	2	50	46	250
87 01 300	034087	30	2 3/4	70	60	300
87 01 400	005636	27	3 1/2	90	95	400
87 01 560	044321	20	4 1/2	115	120	560

Fully open, push, grab!

Additional fast adjustment on the workpiece by sliding the pliers handle

- > Combines the proven, reliable locking of the hinge bolt with an additional push function which makes it easier to work in very confined and inaccessible areas
- > The adjustment directly on the workpiece is possible by simply sliding the pliers handle
- > Reliable locking of the hinge bolt with the first workload. The gripping width of the pliers is then fixed and can only be adjusted by pressing the button.
- > To re-activate the sliding function, the hinge bolt must be released by pressing the push button and the pliers must be completely opened again
- > Chrome vanadium electric steel, forged, multi stage oil-hardened



QuickSet



Article No.	EAN 4003773-	Adjustment positions	Ø Inch	Ø mm	mm	mm
87 21 250	072775	25	2	50	46	250
87 21 300	078524	25	2 3/4	70	60	300
87 22 250	077794	25	2	50	46	250



KNIPEX Cobra® ES

Water Pump Pliers extra-slim

87
5

- > Ideal for service, maintenance and equipment repair, in automotive and general industry
- > Long, narrow jaws
- > Particularly good access to the workpiece due to very slim construction of head and joint area
- > Firm grip also on flat material due to three-point rest
- > Push the button for adjustment on the workpiece



Article No.	EAN 4003773-	Adjustment positions	∅ Inch	∅ mm	mm	↔ mm
87 51 250	061267	19	1 1/4	32	34	250

Siphon- and Connector Pliers

81

For siphons, oil filters, plastic pipes and connectors up to 80 mm diameter

Fine adjustment for ideal adjustment to diverse diameters

- > Ideal for tightening and loosening siphon screw connections, plastic pipe fittings and round union nuts
- > For connectors and couplings with screw connection, such as Cannon circular connectors
- > For gentle loosening of hoses on nozzles
- > 25 adjustment positions, box-joint design

81 01 250 / 81 03 250

- > With serrated gripping jaws; up to ∅ 80 mm

81 11 250 / 81 13 250

- > With exchangeable plastic jaws for sensitive surfaces; up to ∅ 75 mm



81 03 250



81 11 250

Article No.	EAN 4003773-	Working Capacity (diameter) ∅ mm	Adjustment positions	↔ mm
81 01 250	078463	25 – 80	25	250
81 03 250	078487	25 – 80	25	250
81 11 250	078470	10 – 75	25	250
81 13 250	078494	10 – 75	25	250

81 19 250 078500 2 pairs of plastic jaws for 81 11 250 / 81 13 250

Multiple Slip Joint Spanner

87
4

- > For metric and imperial nuts and screws with widths across flats from 10 to 32 mm (3/8" up to 1 1/4"); self-locking from 17 mm: no slipping on the workpiece
- > Zero-backlash gripping of metric or imperial hexagonal headed screws, no rounding of bolt heads
- > Reliable and tight gripping of rounded, rusty, or thick coated bolts and screws



PATENTED

Article No.	EAN 4003773-	Adjustment positions	∅ Inch	∅ mm	↔ mm
87 41 250	054566	15	3/8 – 1 1/4	10 – 32	250

KNIPEX SmartGrip®

Water Pump Pliers with automatic adjustment

85

- > Ideal for frequent changeovers to workpieces of different sizes
- > Automatic adjustment per one-hand operation both for right-handed and left-handed use
- > Good access to the workpiece thanks to the slim dimensions of head and joint area and flush joint bolt
- > Self-locking on pipes and nuts: no slipping on the workpiece and low handforce required



Article No.	EAN 4003773-	∅ Inch	∅ mm	mm	↔ mm
85 01 250	061304	1 1/4	32	36	250

More output and comfort compared to conventional water pump pliers of the same length: 9-notch adjustment positioning for 30% more gripping capacity

Good access to the workpiece due to slim size of head and joint area

- > Self-locking on pipes and nuts: no slipping on the workpiece and low handforce required
- > Gripping surfaces with special hardened teeth, teeth hardness approx. 61 HRC: high wear resistance and stable gripping
- > Box-joint design for high stability due to double guide
- > Robust construction, insensitive to dirt; particularly suitable for outdoor work
- > Guard prevents operators' fingers being pinched
- > Chrome vanadium electric steel, forged, multi stage oil-hardened



Alligator®



Article No.	EAN 4003773-	Adjustment positions	∅ Inch	∅ mm	mm	mm
88 01 180	035480	9	1 1/2	42	36	180
88 01 250	022992	9	2	50	46	250
88 01 300	034094	9	2 3/4	70	60	300
88 01 400	075844	11	3 1/2	90	95	400

KNIPEX Mini pliers sets

in belt tool pouch

00 20

- > Tool bag made of tough polyester fabric, with velcro fastening and belt loop
- > Attractive cardboard packaging with Euro standard perforation
- > Dimensions (W x H x D): 70 x 170 x 50 mm
- > With elastic side holder for small flash lamp, pen or suchlike



Article No.	EAN 4003773-	Content
00 20 72 V01	070832	86 03 150 Mini Pliers Wrench 87 01 125 Cobra® Hightech Water Pump Pliers
00 20 72 V02	075851	74 01 160 High Leverage Diagonal Cutter 87 01 150 Cobra® Hightech Water Pump Pliers

Tool Kits

00 20

Article No.	EAN 4003773-	Content
00 20 09 V02	074793	87 01 180 87 01 250 87 01 300

Article No.	EAN 4003773-	Content
00 20 09 V01	073994	03 02 180 70 02 160 87 01 250

Article No.	EAN 4003773-	Inhalt
00 20 09 V03	074809	88 01 180 88 01 250 88 01 300

Cobra®-Set



Bestseller-Set



Alligator® - Set



Pipe Wrenches 90°

83
10

- > Swedish pattern
- > 90° angled jaws
- > Jaws with offset teeth in opposite direction
- > Teeth additionally induction hardened
- > I-beam handle design
- > Captive adjusting nut
- > Red powder coated, jaws bright ground
- > Chrome vanadium electric steel, forged, multi stage oil-hardened



83 10 015

Article No.	EAN 4003773-	Ø Inch	Ø mm	Ø Inch	mm	↔ mm
83 10 010	014188	1 5/8	42	1	42	310
83 10 015	014195	2 3/8	60	1 1/2	60	420
83 10 020	014201	2 3/4	70	2	70	560

Pipe Wrenches 45°

83
20

- > Swedish pattern
- > 45° angled jaws
- > Jaws with offset teeth in opposite direction
- > Teeth additionally induction hardened
- > I-beam handle design
- > Captive adjusting nut
- > Red powder coated, jaws bright ground
- > Chrome vanadium electric steel, forged, multi stage oil-hardened



83 20 015

Article No.	EAN 4003773-	Ø Inch	Ø mm	Ø Inch	mm	↔ mm
83 20 010	014218	1 5/8	42	1	42	320
83 20 015	014225	2 3/8	60	1 1/2	60	430
83 20 020	014232	2 3/4	70	2	70	570

Pipe Wrenches S-Type

83
30

- > Slim, S-type jaw
- > Jaws with offset teeth in opposite direction
- > Teeth additionally induction hardened
- > Three-point contact on pipes, self-locking
- > I-beam handle design
- > Captive adjusting nut
- > Red powder coated, jaws bright ground
- > Chrome vanadium electric steel, forged, multi stage oil-hardened



83 30 015

Article No.	EAN 4003773-	Ø Inch	Ø mm	Ø Inch	↔ mm
83 30 010	014249	1 5/8	42	1	320
83 30 015	014256	2 3/8	60	1 1/2	420
83 30 020	014263	2 3/4	70	2	540

Pipe Wrenches S-Type with fast adjustment

83
6

- > Time-saving, precise adjustment of the gripping width directly on the workpiece at the push of a button
- > Less effort required due to self-locking action
- > No unintentional shifting of the pliers handles
- > Guard prevents operators' fingers being pinched
- > Maximum load capability thanks to completely hardened handles
- > High wear resistance due to the additionally hardened teeth
- > Chrome vanadium electric steel, forged, multi stage oil-hardened



83 60 010

Article No.	EAN 4003773-	Ø Inch	Ø mm	Ø Inch	↔ mm
83 60 010	075424	1 5/8	42	1	330
83 60 015	075677	2 3/8	60	1 1/2	420
83 60 020	078838	2 3/4	70	2	560
83 61 010	077602	1 5/8	42	1	330
83 61 015	077619	2 3/8	60	1 1/2	420
83 61 020	078876	2 3/4	70	2	560

Needle-Nose Combination Pliers

08

Handy use when working in confined areas thanks to slim head design and pointed jaws (anti-twist)

Gripping surfaces with special convex contour on one side for secure gripping of flat parts

Milled groove in the gripping area permits small parts such as nails, pins and bolts to be held and pulled

- > The reliable and diverse combination pliers when out and about
- > Easy cutting thanks to the high leverage joint
- > With cutting edges for soft, medium-hard and hard wire
- > Long service life and stable tips
- > Forged from special high grade tool steel, manifold oil-hardened



Article No.	EAN 4003773-	Ø mm	Ø mm	Ø mm	mm ²	↔ mm
08 21 145	078951	3	2	8	16	145
08 22 145	078968	3	2	8	16	145
08 25 145	078975	3	2	8	16	145
08 26 145	079361	3	2	8	16	145



08 21 145



08 22 145



08 25 145

Milled groove in the gripping area

Firm grip also on flat material due to three-point rest

Tip keeps its shape even during greater torsional forces



Combination Pliers

03

- > With gripping zones for flat and round material, suitable for versatile use
- > With cutting edges for soft and hard wire
- > Long cutting edges for thicker cables
- > Cutting edges additionally induction hardened, cutting edge hardness approx. 60 HRC
- > Special tool steel, forged, multi stage oil-hardened



03 02 180



Article No.	EAN 4003773-	Ø mm	Ø mm	Ø mm	mm ²	↔ mm
03 02 160	023203	3.1	2.0	10.0	16.0	160
03 02 180	023197	3.4	2.2	12.0	16.0	180
03 02 200	034940	3.8	2.5	13.0	16.0	200
03 06 200	033776	⚡ 1000 V	2.5	13.0	16.0	200

High Leverage Combination Pliers

02

35% less effort required than with conventional combination pliers
With cutting edges (hardness approx. 63 HRC) for heavy duty

- > Easier work due to optimised leverage
- > Easier cutting, powerful gripping, bending and pulling
- > Long cutting edges for thicker cables
- > With gripping zones for flat and round material, suitable for versatile use
- > High-grade special tool steel, forged, multi stage oil-hardened



02 02 180

Article No.	EAN 4003773-	Ø mm	Ø mm	Ø mm	mm ²	↔ mm
02 02 180	034896	2.5	2.0	11.5	16.0	180
02 02 200	034902	2.8	2.2	13.0	25.0	200
02 02 225	043379	3.0	2.5	14.0	25.0	225

Diagonal Cutters

70

- > The indispensable diagonal cutter for all-round use
- > High-quality material and precise workmanship for long service life
- > Precision cutting edges for soft and hard wire
- > Clean cutting of thin copper wires, also at the cutting-edge tips
- > Cutting edges additionally induction hardened, cutting edge hardness approx. 62 HRC
- > Narrow head style for use in confined areas
- > Vanadium electric steel, forged, multi stage oil-hardened



Precision rivet:
new and more stable rivet shape

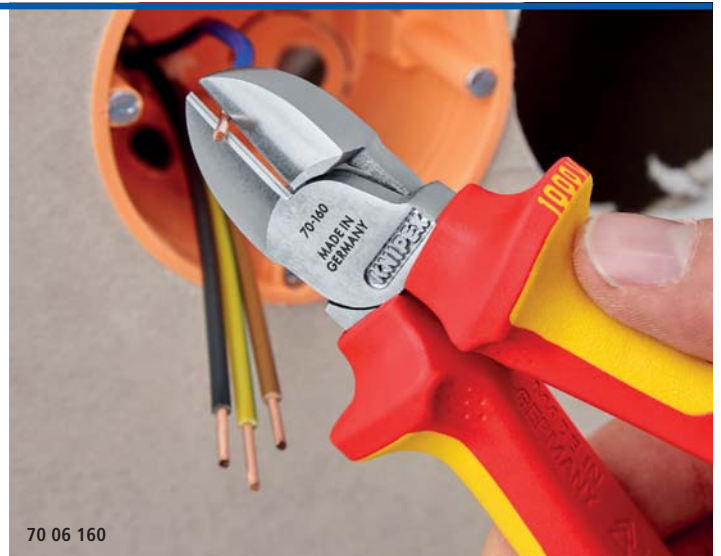

70 06 160

1000 V



Clean cutting of thin copper wires, –

also at the cutting-edge tips



Article No.	EAN 4003773-					
		Ø mm	Ø mm	Ø mm	Ø mm	mm
70 02 125	034025	3.0	2.3	1.5	1.5	125
70 02 140	023098	4.0	2.5	1.8	1.8	140
70 02 160	034032	4.0	3.0	2.0	2.0	160
70 02 180	034049	4.0	3.0	2.5	2.5	180
70 06 160	021995		4.0	3.0	2.0	160

KNIPEX X-Cut®

Compact Diagonal Cutters

73
0

Powerful, light and universal

Cuts finest strands as well as multi-core cables and piano wires

- > Box-joint design: highest stability with low weight
- > High cutting performance with minimum effort due to optimum co-ordination of the cutting edge angle and transmission ratio
- > Large opening width for thicker cables
- > Cuts precisely, even through fine copper wires
- > Compact, low-weight construction
- > Doubly supported joint axis for heaviest duty

40% less force required

Compared with standard diagonal cutters of the same length.
With doubly supported joint axis.

Article No.	EAN 4003773-								
		Ø mm	Ø mm	Ø mm	Ø mm	Ø mm	Ø mm	Ø mm	mm
73 02 160	075127	4.8	3.8	2.7	2.2	12.0	12.0	12.0	160
73 05 160	075134	4.8	3.8	2.7	2.2	12.0	12.0	12.0	160
73 06 160	075141		4.8	3.8	2.7	2.2	12.0	12.0	160



High Leverage Diagonal Cutters

74

- > For very tough, continuous use
- > High cutting performance with minimum effort due to optimum co-ordination of the cutting edge angle and transmission ratio
- > Precision cutting edges additionally induction hardened (cutting edge hardness approx. 64 HRC), for all sorts of wire including piano wire
- > Chrome vanadium heavy-duty steel, forged, multi stage oil-hardened









74 02 160



74 02 180



74 06 200

Article No.	EAN 4003773-	 Ø mm	 Ø mm	 Ø mm	 mm	
74 02 160	023081	3.4	2.5	2.0	160	
74 02 180	023074	3.8	2.7	2.2	180	
74 02 200	040309	4.2	3.0	2.5	200	
74 02 250	042402	4.6	3.5	3.0	250	
74 06 200	033820	 1000V 	4.2	3.0	2.5	200



KNIPEX TwinForce®

High Performance Diagonal Cutters

73
72

The superior High-Leverage Diagonal Cutter with patented double joint

- > Ideal transmission of force due to double-hinged design
- > Reliably cuts all types of wire, including steel tape
- > For rough or very fine cutting
- > Low cutting impact: gentle on hands. The tension on muscles and tendons is relieved
- > For comfortable cutting, repetitive cutting or extremely hard cutting jobs
- > High degree of stability and zero-backlash due to precisely milled forged-in axles
- > Chrome vanadium heavy-duty steel, forged, oil-hardened





73 72 180 F:

- > With opening spring to simplify reapplication and for repetitive cutting



73 71 180



Article No.	EAN 4003773-	 Ø mm	 Ø mm	 Ø mm	 Ø mm	 mm
73 71 180	074762	5.5	4.6	3.2	3.0	180
73 72 180	074779	5.5	4.6	3.2	3.0	180
73 72 180 F	077657	5.5	4.6	3.2	3.0	180

Extremely easy cutting with little strain: cuts again 50 % easier than the tried and tested KNIPEX high leverage diagonal cutters

Electricians' Pliers

13
0

- > The ideal pliers for cable work
- > For gripping and bending wire
- > For cutting medium hard and hard wire
- > Precision cutting edges additionally induction hardened, cutting edge hardness approx. 60 HRC
- > With precision stripping holes
- > For crimping end sleeves (ferrules)

Article No.	EAN 4003773-	Stripping capacities mm ²	Ø mm	Ø mm	↔ mm
13 01 160	034971	0.5 – 0.75 / 1.5 / 2.5	2.5	1.6	160
13 02 160	010470	0.5 – 0.75 / 1.5 / 2.5	2.5	1.6	160



13 02 160

Pliers for Electrical Installation

13

6 functions in one pair of pliers

Multifunctional pliers for the electrical installation; to grip flat and round material, for bending, deburring, cutting cable, stripping and crimping end sleeves (ferrules)

- > Smooth surfaces near the tips grip single cores without damaging them; serrated gripping surfaces and pipe grip for gripping flat and round material
- > Clear-cut outside edge on the jaw for working on flush-mounted junction boxes and deburring feed-through holes
- > Stripping holes for conductors of 0.75 – 1.5 mm² and 2.5 mm²
- > Crimp die for wire-end ferrules 0.5 – 2.5 mm²
- > Cable shears with (induction-hardened) precision cutting edges for copper and aluminium cables up to 5 x 2.5 mm²/dia. 15 mm
- > Slim dimensions for easy access
- > Bolted joint: precise, zero backlash operation of pliers
- > High-grade special tool steel, forged, multi stage oil-hardened

13 91 200 / 13 92 200 / 13 96 200

- > The intelligent latching mechanism enables you to «grip» without opening the pliers. The cutting edge remains closed and protected.

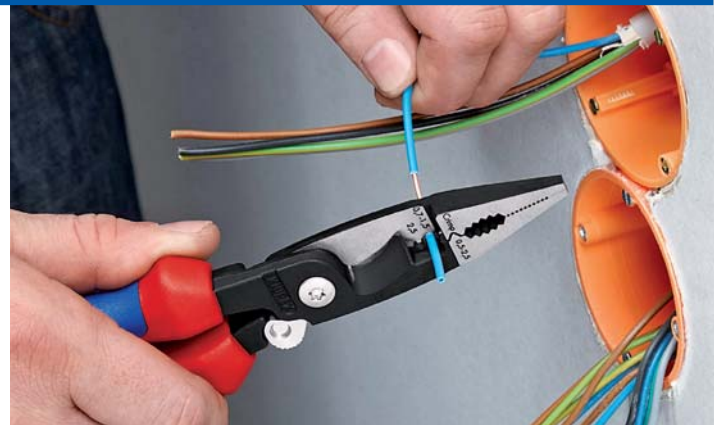

13 92 200
MM



13 86 200

Article No.	EAN 4003773-	Grips	Capacity in square		↔ mm
			Ø mm	mm ²	
13 81 200	075240	plastic coated	15	50	200
13 82 200	075080	multi-component grips	15	50	200
13 86 200	075097	multi-component grips, VDE-tested	15	50	200
13 91 200	075257	plastic coated	15	50	200
13 92 200	075103	multi-component grips	15	50	200
13 96 200	075110	multi-component grips, VDE-tested	15	50	200

Cable Shears

95

- > For cutting copper and aluminium single conductors as well as multiple stranded cables
- > Not suitable for steel wire and hard drawn copper conductors
- > Precision ground, hardened blades
- > Clean and smooth cut without crushing and deformation

95 26 165

- > Internal opening spring, protected and captive

95 41 165

- > Universal stripping area for both solid conductor cross-sections

Cable Shears with twin cutting edge

PATENTED

- > Initial and final cut (upper and lower blade) allows cables of up to 20 mm dia. to be cut
- > Low handforce required due to favourable lever ratio and special blade geometry

Article No.	EAN 4003773-		Ø mm	mm ²	AWG	↔ mm
95 11 165	040323		15	50	1/0	165
95 12 165	029182		15	50	1/0	165
95 16 165	039648	⚡ 1000 V	15	50	1/0	165
95 26 165	069980	⚡ 1000 V	15	50	1/0	165
95 16 200	026761	⚡ 1000 V	20	70	2/0	200
95 41 165	078609		12	35	1/0	165



95 41 165



95 26 165



95 16 200



Initial cut



Final cut

KNIPEX TwinKey®

for all standard cabinets and shut-off systems

00
1

10 profiles. 2 crosses. 1 key.

All common locking systems

- > Multifunctional key for the actuation of locking systems from the areas of facilities engineering (heating and sanitation, air conditioning, electro technology), gas and water supply and shut-off-systems
- > 8-arm version: two 4-way spider keys connected in a space-saving way using magnets
- > Reversible bit: 1.0 x 7 mm slot and PH2 cross slot
- > Key and reversible bit joined by stable stainless steel wire

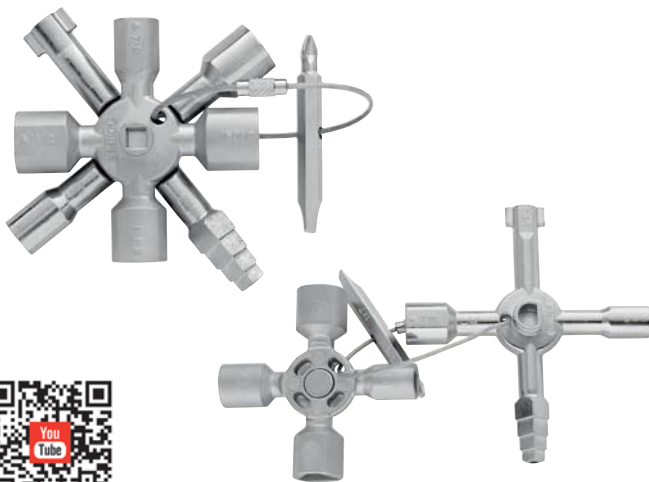

Article No.	EAN 4003773-	mm	mm	Ø mm	mm	mm	↔ mm
00 11 01	074670	5 / 6 - 7 / 8 - 9 / 10 - 11	7 - 8 / 9 - 10 / 11 - 12	3 - 5	6	6 - 9	95



Micro-structured cutting edge allows easy cutting of large cross-sections

With gripping surface below the joint for gripping and pulling wires with a diameter as from 1.0 mm

- > Precision cutting edges for soft and hard wire as well as piano wire
- > Cuts bolts, nails, rivets, etc. up to 5.2 mm dia.
- > Most efficient joint design ensures exceptional cutting performance with little effort
- > Cutting edges additionally induction hardened, cutting edge hardness approx. 64 HRC
- > Chrome vanadium heavy-duty steel, forged, multi stage oil-hardened

71 12 200 / 71 22 200 / 71 32 200

- > Opening spring and locking device are integrated in the handles also for comfortable work and protected transport

71 32 200

- > The recess in the blade allows easier cutting of thicker wires, e. g. for anchor bolts in false ceilings



71 01 / 02 / 12 200
Micro-structured cutting edge

71 01 / 02 / 12 und 71 32 200
Gripping surface below the joint

Article No.	EAN 4003773-						
			Ø mm	Ø mm	Ø mm	Ø mm	mm
71 01 200	033165		6.0	5.2	4.0	3.6	200
71 02 200	047056		6.0	5.2	4.0	3.6	200
71 12 200	066859	///	6.0	5.2	4.0	3.6	200
71 32 200	066880	///	6.0	5.2	4.0	3.6	200



Combination Shears

- > For cutting cardboard, plastics, aluminium, brass and copper foils
- > Not suitable for steel wire or iron sheets
- > Precision ground, hardened blades
- > With opening spring and locking device
- > Guard prevents operators' fingers being pinched
- > Adjustable bolted joint

Article No.	EAN 4003773-	
		mm
95 05 190	019602	190



Self-Adjusting Insulation Strippers

- > For single, multiple and fine stranded conductors with plastic or rubber insulation
- > Adapts automatically to the respective cable cross-section; prevents damage to the conductor
- > Cutting depth can be adjusted for different insulation materials
- > With wire cutter for copper and aluminium wires, multiple stranded up to 10 mm² and single stranded up to 6 mm²
- > Smoothly operating mechanism



Article No.	EAN 4003773-		Stripping capacities		
			mm ²	AWG	
12 40 200	026662	///	0.03 – 10	32 – 7	200

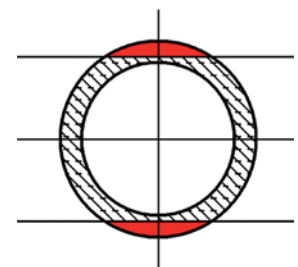

Mode of operation of straight cutters

An incision is made in the red area only.

Not suitable for highly-flexible or armoured insulation materials or for multi-layered insulation.

KNIPEX MultiStrip 10 Automatic Insulation Stripper

12
42

Stripping without re-adjustment from 0.03 to 10.0 mm²

PATENTED

Universal blade geometry – robust and more durable

Ideal grip design with excellent haptics

Recessed wire cutter

- > Fully automatic adjustment to all single-, multi- and fine-stranded conductors with standard insulation throughout the entire capacity range from 0.03 to 10.0 mm²
- > No manual fine adjustment necessary
- > No damage to the conductors
- > The clamping jaws made of steel hold the cable in a way that prevents slipping without damaging the remaining insulation
- > With recessed wire cutter for Cu and Al conductors, stranded up to 10 mm² and single wire up to 6 mm²
- > Particularly smooth-running mechanics and very low weight
- > Replaceable blades block and length stop
- > Handle with soft-plastic zone for a steady grip
- > Body: plastic, fibreglass-reinforced
- > Blade: special tool steel, oil-hardened

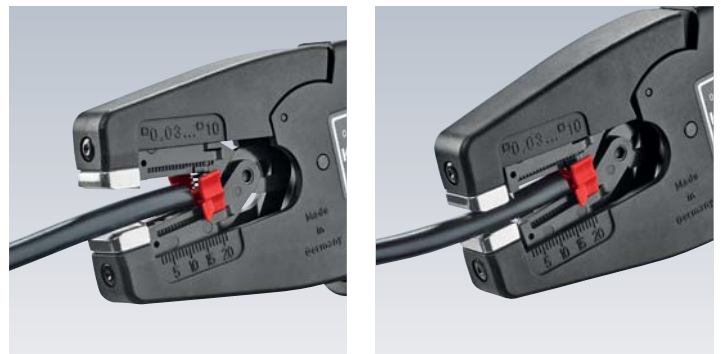

Article No.	EAN		Stripping capacities		↔ mm
			mm ²	AWG	
12 42 195	4003773-054580	MM	0.03 – 10	32 – 7	195

Automatic Insulation Stripper

12
62

- > Compact standard tool at a favourable price for all current cable cross-sections and insulating materials
- > For single, multiple and fine stranded cables of 0.2 up to 6 mm² with standard insulation
- > Adapts automatically to the respective cable cross-section; prevents damage to the conductor
- > Handy shape and low weight provide high operation comfort
- > Narrow head style for use in confined areas
- > With wire cutter for copper and aluminium wires up to 2.5 mm²
- > With adjustable length stop from 6.0 – 18.0 mm for cutting the same stripping lengths during repetitive work
- > Body: plastic, fibreglass-reinforced
- > Blades: special tool steel, oil-hardened, interchangeable



Precise stripping from 0.2 up to 6.0 mm²



Wire cutter up to 2.5 mm²



Article No.	EAN		Stripping capacities		↔ mm
			mm ²	AWG	
12 62 180	4003773-054573	MM	0.2 - 6	24 - 10	180

KNIPEX ErgoStrip® Universal Dismantling Tool

16
95

For the fast and precise dismantling and stripping of all common round and damp-proof installation cables (e.g. NYM cable 3 x 1.5 mm² up to 5 x 2.5 mm²), data cable (e.g. twisted pair) and coax cable

Innovative, ergonomic pistol grip design for easy cutting, stripping and longitudinal cut of the sheath

- > Conical, slimmed down tool ends for better access in confined areas
- > Stripping device for cross-sections 0.2/0.3/0.8/1.5/2.5/4 mm²
- > Simplified insertion of single wires for stripping using location ridges
- > With opening spring and locking device
- > Easy insertion of coax and data cable thanks to opening aid
- > Multi-component design with a soft plastic zone for comfortable use and a secure grip
- > Housing made from stable glass fibre reinforced plastic



Dismantling of a NYM cable

Stripping of a coax cable

Wire stripping on single conductors



PAT. PEND.

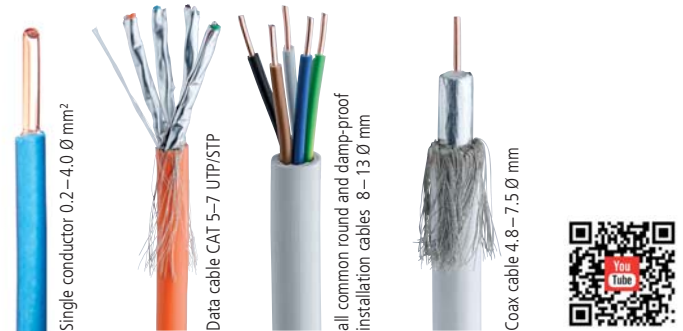

Article No.	EAN 4003773- 079927	Stripping capacities				↔ mm
		Round cable Ø mm	Conductors and strands mm ²	Data cable	Coax cable Ø mm	
16 95 01 SB	079927	8 - 13	0.2 - 4.0	CAT 5 - 7. Twisted-Pair (UTP/STP)	4.8 - 7.5	135

Universal Dismantling Tools

16

- > For dismantling and stripping all common round and damp-proof installation cables between 8.0 - 13.0 mm dia. (e.g. 3 x 1.5 mm² up to 5 x 2.5 mm²)
- > Also for use in conduit and distribution boxes
- > Double shell, folding back stripping tool
- > With opening spring and locking device
- > Practical clip for easy transport
- > Body: plastic, fibreglass-reinforced

16 85 125 SB:

- > With additional blade for longitudinal cuts
- > Telescopic blade inside
- > Stripping device for cross-sections 0.2/0.3/0.8/1.5/2.5/4 mm²
- > With integrated cable guide for longitudinal cut. This enables rigid insulation (e.g. halogen-free) to be stripped more easily

Article No.	EAN 4003773-	Stripping capacities Ø mm	Types of cables	↔ mm
16 80 125 SB	040828	8.0 - 13.0	Round cable, e.g.: 3 x 1.5 mm ² up to 5 x 2.5 mm ²	125
16 85 125 SB	060444	8.0 - 13.0	Round cable, e.g.: 3 x 1.5 mm ² up to 5 x 2.5 mm ²	125
16 90 130 SB	076940	8.0 - 13.0	Round cable, e.g.: 3 x 1.5 mm ² up to 5 x 2.5 mm ²	130



16 80 125 SB



16 85 125 SB



16 90 130 SB

KNIPEX MultiCrimp®

Crimping Pliers with changer magazine

97

Also for insulated and non-insulated end sleeves (ferrules)
10 / 16 / 25 mm²

Universal indent crimping die for non-insulated connectors

- > Just one tool for the most common crimping applications
- > Crimping dies changed quickly and easily without any additional tool
- > Sorted and protected storage of the interchangeable dies in a round magazine
- > Comfortable, powerful crimping pliers in professional quality
- > Same reliable crimping results as with fixed crimping dies
- > Repetitive, high crimping quality due to precision dies and integral lock (self-releasing mechanism)



97 33 02



Article No.	EAN				Capacity mm ²	AWG	↔ mm
97 33 02	4003773-066934			MMM	KNIPEX MultiCrimp®		250
					non-insulated open plug type connectors (plug width 4.8 + 6.3 mm)	0.5 – 1 1.5 – 2.5 4 – 6	20 – 10
					insulated terminals, plug connectors + butt connectors	0.5 – 1 1.5 – 2.5 4 – 6	20 – 10
					End Sleeves (ferrules)	0.25 – 0.75 1 – 1.5 2.5 4 6	23 – 10
					End Sleeves (ferrules)	10 / 16 / 25	7 / 5 / 3
					non-insulated crimp terminals, tube and compression cable lugs in accordance with DIN 46234 and DIN 46235 and non-insulated crimp, butt and press connectors in accordance with DIN 46341 and DIN 46267	0.5 – 1 1.5 – 2.5 4 – 6 10	20 – 7

Crimping Pliers

for end sleeves (ferrules)

97
7

Easy crimping due to optimised transmission ratio

Light and slim design

- > For crimping end sleeves (ferrules) according to DIN 46228 parts 1 + 4 from 0.25 to 16 mm²
- > Crimping in marked half-round dies for reliable connections between the sleeve and the conductor
- > 9 particularly deep dies with conical side faces
- > Special tool steel, forged, oil-hardened



97 71 180

Article No.	EAN			Capacity		Number of crimping positions	↔ mm
				mm ²	AWG		
97 71 180	040668			0.25 – 16	23 – 5	9	180
97 78 180	072003			0.25 – 16	23 – 5	9	180

KNIPEX PreciForce®

Crimping Pliers

97
5

- > Repetitive, high crimping quality due to precision dies and integral lock (self-releasing mechanism)
- > Crimping pressure has been set precisely (calibrated) in the factory, re-adjustable
- > Optimum transmission of force thanks to toggle lever for fatigue-reduced operation
- > Good handling thanks to favourable handle position, low weight, compact design and ergonomically shaped handles



97 52 33



Article No.	EAN	Applications	Capacity mm ²	AWG	Number of crimping positions	↔ mm
97 52 33	051862	non-insulated crimp terminals, tube and compression cable lugs in accordance with DIN 46234 and DIN 46235 and non-insulated crimp, butt and press connectors in accordance with DIN 46341 and DIN 46267	0.5 – 10	20 – 7	4	220
97 52 36	051893	insulated terminals, plug connectors + butt connectors	0.5 – 6	20 – 10	3	220
97 52 38	051909	insulated and non-insulated end sleeves (ferrules)	0.25 – 6	23 – 10	5	220

Self-Adjusting Crimping Pliers for end sleeves (ferrules)

with lateral access

97
53

Square compression now additionally also for end sleeves (ferrules) up to 16 mm²



Crimping capacity can be switched over simply from 10 mm² to 16 mm².



97 53 04



Suitable in particular for all twin end sleeves (ferrules) up to 2 x 6 mm² or 2 x AWG 8
0.08 - 10 mm² + 16 mm²



Square compression for ideal contact surfaces in the clamp connection

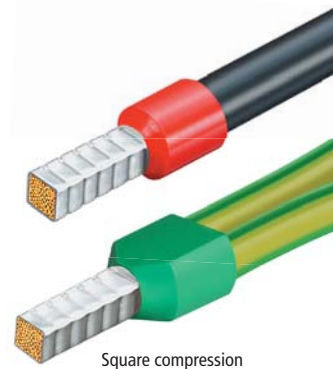

The small crimping pliers for end sleeves (ferrules) with two major advantages for the user:

- > Automatic adjustment to the end sleeves used: This makes work easier for the professional and offers reliable and fast crimping.
- > Expanded range of applications

Proven functions

- > For crimping end sleeves (ferrules) according to DIN 46228 parts 1 + 4
- > Self-adjusting adaptation to the desired end sleeve (ferrule) size: no wrong crimps caused by using the wrong die
- > Repetitive, high crimping quality due to integral lock (self-releasing mechanism)
- > Tools have been set precisely (calibrated) in the factory
- > Optimum transmission of force thanks to toggle lever for fatigue-reduced operation
- > Handy shape and low weight provide high operation comfort

Expanded capacity of hexagonal crimping up to 10 mm²



97 53 14



Suitable in particular for all twin end sleeves (ferrules) up to 2 x 4 mm² or 2 x AWG 10
0.08 - 10 mm²



for confined connection dimensions

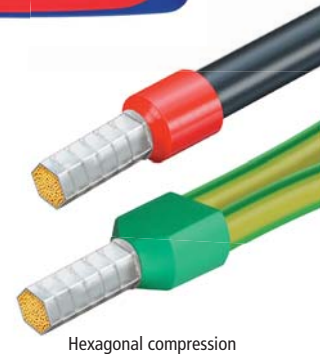

Article No.	EAN			Pliers	Handles	Applications	Capacity mm ²	AWG	↔ mm
97 53 04	028017			burnished	with multi-component grips	End Sleeves (ferrules)	0.08 - 10 + 16	28 - 5	180
97 53 14	041474			burnished	with multi-component grips	End Sleeves (ferrules)	0.08 - 10	28 - 7	180

Pipe Cutter

for plastic conduit pipes and hoses

90
2

- > For cutting thin walled plastic pipes (conduit plastic pipes) and flexible hoses, also with fabric reinforcement, of plastic and rubber up to 25.0 mm/1" exterior dia.
- > Not suitable for cutting cables
- > With opening spring and locking device
- > Tool body: plastic, fibreglass-reinforced
- > Blades: special tool steel, oil-hardened, interchangeable



Article No.	EAN 4003773-	Cutting capacities Ø mm	↔ mm
90 20 185	067122	25	185



Pipe Cutter

for composite pipes and protective tubes

90

- > For cutting composite pipes with diameters from 12.0 to 25.0 mm and for cutting flexible protective tubes with a diameter of 18.0 – 35.0 mm without damaging a potential pipe inside
- > A calibration arbor can be fitted, for example for Geberit composite pipes with 11.5 and 15.0 mm dia.
- > Tool body: high-grade chrome vanadium electric steel, oil-hardened



Article No.	EAN 4003773-	Cutting capacities composite pipes Ø mm	Cutting capacities protective tubes Ø mm	↔ mm
90 25 20	046004	12 – 25	18 – 35	210

Pipe Cutter

for composite and plastic pipes

90

- > For cutting thick walled plastic and composite pipes with diameters from 26.0 to 40.0 mm
- > Cuts pipes using the ratchet principle in several strokes
- > Self-adapting pipe support positions pipes of various diameters correctly for a rectangular cut



Article No.	EAN 4003773-	Cutting capacities Ø mm	↔ mm
90 25 40	045182	26 – 40	210

Pipe Cutter for plastic conduit pipes

94

- > For clean cutting of plastic pipes (e.g. plastic conduit pipes) with 6.0 – 35.0 mm dia.
- > Not suitable for cutting cables
- > Blade is replaceable and can be retracted from any position
- > Low force requirement due to special blade geometry and optimum transmission
- > Minimum operator fatigue due to ergonomic handle design and incremental ratchet blade feed



Article No.	EAN 4003773-	Cutting capacities Ø mm	Cutting edge length mm	↔ mm
94 10 185	047025	6 – 35	35	185

Notching Pliers

90
6

- > Special pliers for notching recesses into plastic ledges and plastic casings for electric and sanitary installation
- > Notches can be enlarged by initial and final cut
- > Clean cut edges – no trimming activities needed
- > Easy handling
- > With opening spring, opening limiter and locking lever
- > Pliers body: special tool steel, rolled, oil-hardened



Article No.	EAN 4003773-	Capacity mm	↔ mm
90 61 16	051947	16 x 32	250

KNIPEX L-BOXX® Plumbing 52 parts

NEW

- > Equipped with 52 brand name quality tools, some VDE tested according to DIN EN 60900
- > Several boxes can be securely joined together
- > Flexible inner partitions
- > With two-part tool holder made of hard-wearing polyester fabric
- > Tool holders are connected to each other using hook-and-loop
- > Handle can be lowered into a hollow in the lid to save space
- > Ergonomically shaped handles with additional moulded recess on the side for flexible, convenient handling
- > Dimensions, exterior (W x H x D): 442 x 151 x 357 mm; dimensions, interior (W x H x D): 375 x 107 x 311 mm
- > Strong box made of impact- and shock-proof ABS plastic

Article No.	EAN 4003773-	Content
00 21 19 LB S	081630	1 x 00 11 01 / 1 x 26 16 200 / 1 x 74 06 180 1 x 86 03 250 / 1 x 87 01 250 / 1 x 87 01 400 1 x 98 20 35 / 1 x 98 20 55 / 1 x 98 26 15 1 x 98 26 20 / 1 x 98 26 25 / 1 x 98 24 01 1 x 98 24 02 / 1 x 361 252 1 / 1 x 005655 1 x 004018 / 1 x 003760 / 1 x 022086 / 1 x 90958 1 x 16640003 / 1 x 101-0300 / 1 x 340 250 1 1 x 02281 / 1 x 71510-000 / 1 x 6135-0
00 21 19 LB	081616	empty
00 21 19 LB WK	081609	Two-part tool holder



00 21 19 LB S



00 21 19 LB WK

Plumber's tool case 52 parts

- > Strong tool case for professional use
- > For extensive plumbing and installation work
- > Equipped with 52 brand tools

Article No.	EAN 4003773-	Content
00 21 21 HK S	080671	1 x 86 03 250 / 1 x 87 01 250 / 1 x 887 01 400 1 x 74 06 180 / 1 x 26 16 200 / 1 x 00 11 01 1 x 006110 / 1 x 006120 / 1 x 006172 / 1 x 006174 / 1 x 006176 / 1 x 006152 / 1 x 006154 1 x 018266 / 1 x 018268 / 1 x 005655 / 1 x 004018 1 x 003760 / 1 x 022086 / 1 x 90958 / 1 x 16640003 / 1 x 101-0300 / 1 x 340 250 1 1 x 02281



00 21 41

Tool Case empty

Tool Case „BIG Twin“ empty

- > Heavy duty ABS material, black
- > 30 kg maximum load
- > Removable document compartment and removable tool board

Article No.	EAN 4003773-	Content
00 21 40 LE	057673	Tool Case „BIG Twin“ empty
00 21 41 LE	071549	Tool Case „BIG Twin-Move“ with integrated rollers and telescopic handle, empty
00 21 40 T	062981	Telescopic handle for 00 21 40 LE / 98 99 14



00 21 40 LE

00 21 40 T

00 21 05 LE

Article No.	EAN 4003773-	Content
00 21 05 LE	056904	Tool Case „Basic“, empty

Tool Bag, empty

Article No.	EAN 4003773-	Content
00 21 02 LE	057499	Tool Bag „New Classic Basic“, empty
00 21 11 LE	077718	Tool Bag, empty



00 21 02 LE

00 21 11 LE

KNIPEX-Werk
C. Gustav Putsch KG

42337 Wuppertal
Germany

Tel.: +49 (0) 202 – 47 94 0
Fax: +49 (0) 202 – 47 74 94

info@knipex.com
www.knipex.com

Your dealer